

FIBERGLASS CONDUIT

WHY SHOULD YOU CONSIDER USING FIBERGLASS REINFORCED EPOXY CONDUIT?

Fiberglass conduit offers many advantages over other commonly used conduit, such as steel and PVC, as listed below:

EASE OF ASSEMBLY:

Epoxy fiberglass conduit is easy to install, partly resulting from its light weight, which facilitates handling. Fitting sections together using the push-fit spigot and bell design further facilitates assembly.

LIGHTWEIGHT:

Epoxy fiberglass conduit weighs considerably less than PVC or steel, resulting in cost savings through reduced handling time, reduced assembly time, reduced requirements for mechanized handling, reduced freight charges, reduced system weight, and lower costs of support. By way of example, one hundred ft. of 4" FRE® conduit weighs in at 282 pounds, compared with almost 1,000 pounds for steel. The high flexural strength of FRE® Conduit combined with its light weight allows for much greater span distance between supports hence reducing overall weight and costs.

LOW COEFFICIENT OF FRICTION:

The coefficient of friction of epoxy fiberglass is lower than that of steel, and considerably lower than that of PVC. This means that electrical cables are easier to pull through, resulting in labour savings, less stress on cables, and reduces the number of costly manholes. As FRE®'s minimum resin content is higher than industry standards, FRE®'s coefficient of friction is the lowest and product longevity is the best in the industry.

TEMPERATURE RANGE:

FRE® Conduit can withstand a wide array of temperature ranging from -40°F to 230°F (-40°C to 110°C). Unlike PVC which is extremely brittle in cold temperature (+40°F) and malleable in heat, FRE® Conduit maintains its unique characteristics.

NO BURN-THROUGH:

Unlike rigid PVC, epoxy fiberglass bends and elbows have a strong resistance to being cavitated or pierced as a result of rope pull.

CABLE FUSION:

Fiberglass is an excellent insulator. Unlike fiberglass conduit, steel conduit will weld with cable, and PVC conduit may fuse or melt under electrical fault conditions.

FLEXIBLE AND IMPACT RESISTANT:

The flexibility of epoxy fiberglass conduit allows it to conform to mildly uneven surfaces. Epoxy fiberglass conduit has tended to survive the stresses of earthquakes better than PVC or steel.

CORROSION RESISTANT:

Epoxy fiberglass is not affected by the effects of water or most other chemicals.

NON-TOXIC:

Unlike PVC, epoxy fiberglass is low halogen and does not release bromine or chlorine.



Standard colors for Fiberglass are Black and Gray. Other colors are available. Ask your local Vikimatic representative for details.

ID/IPS EXTRA HEAVY WALL (XHW) CONDUIT

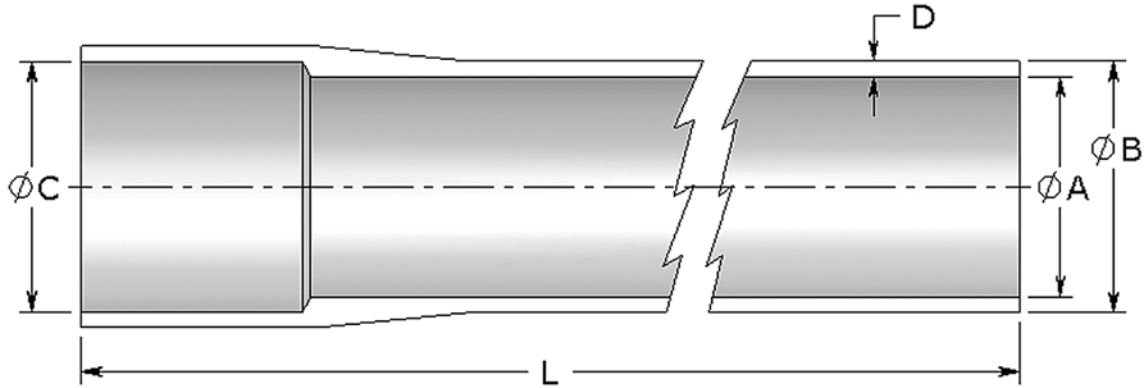

	Size		ØA	ØB	ØC	D	L	ØA	ØB	ØC	D	L
	in	mm										
▶	2	51	2.000	2.500	2.540	0.250	236.25	50.8	63.5	64.5	6.4	6
▶	3	76	3.000	3.500	3.540	0.250	236.25	76.2	88.9	89.9	6.4	6
▶	4	102	4.000	4.500	4.540	0.250	236.25	101.6	114.3	115.3	6.4	6
▶	5	127	5.000	5.500	5.540	0.250	236.25	127.0	139.7	140.7	6.4	6
▶	6	152	6.000	6.500	6.540	0.250	236.25	152.4	165.1	166.1	6.4	6
+	8	203	8.393	8.893	8.933	0.250	236.25	213.2	225.9	226.9	6.4	6

▶ **All ID Telecom products are offered with a push-fit assembly requiring adhesive.**

▶ Standard length is 19.68 ft. (6m) but can also be available in 9.84 ft. section (3m), if required.

▶ Spigot end tapered for ease of installation.

+ **All IPS Telecom products are offered with a push-fit assembly requiring adhesive.**

+ Standard length is 19.68 ft. (6m) for 8" (203mm) but can also be available in 9.84 ft. section (3m), if required.

+ Spigot end tapered for ease of installation.

Part Number Ordering Matrix Begins On Page 90

FIBERGLASS CONDUIT

ID/IPS XHW DOUBLE BELL COUPLING

► ID Product
+ IPS Product

	Size		ØC	D	L	ØC	D	L
	in	mm		inches		millimeters		
►	2	51	2.540	0.250	8.5	64.5	6.4	215.9
►	3	76	3.540	0.250	8.5	89.9	6.4	215.9
►	4	102	4.540	0.250	8.5	115.3	6.4	215.9
►	5	127	5.540	0.250	8.5	140.7	6.4	215.9
►	6	152	6.540	0.250	8.5	166.1	6.4	215.9
+	8	203	8.933	0.250	8.5	226.9	6.4	215.9

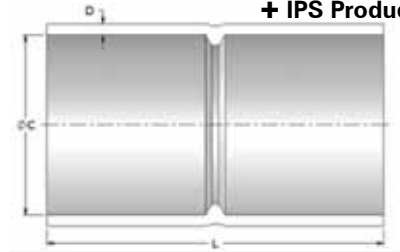

ID/IPS XHW 5° DOUBLE BELL COUPLING

	Size		ØC	D	L	ØC	D	L
	in	mm		inches		millimeters		
►	2	51	2.540	0.250	0.125	64.5	6.4	3.2
►	3	76	3.540	0.250	0.125	89.9	6.4	3.2
►	4	102	4.540	0.250	0.125	115.3	6.4	3.2
►	5	127	5.540	0.250	0.125	140.7	6.4	3.2
►	6	152	6.540	0.250	0.125	166.1	6.4	3.2
+	8	203	8.933	0.250	0.125	226.9	6.4	3.2

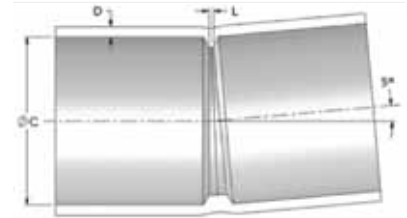

ID/IPS XHW SLEEVE

	Size		ØC	D	L	ØC	D	L
	in	mm		inches		millimeters		
►	2	51	2.540	0.250	12	64.5	6.4	304.8
►	3	76	3.540	0.250	12	89.9	6.4	304.8
►	4	102	4.540	0.250	12	115.3	6.4	304.8
►	5	127	5.540	0.250	12	140.7	6.4 <td 304.8	
►	6	152	6.540	0.250	12	166.1	6.4	304.8
+	8	203	8.933	0.250	12	226.9	6.4	304.8



ID/IPS XHW SINGLE EXPANSION JOINT

Part Number Ordering Matrix Begins On Page 90

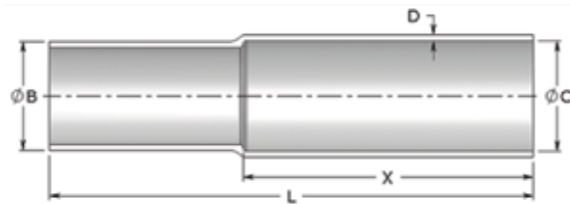

	Size		ØB	ØC	D	L	X	ØB	ØC	D	L	X
	in	mm			inches			millimeters				
►	2	51	2.500	2.540	0.250	20	12	63.5	64.5	6.4	508.0	304.8
►	3	76	3.500	3.540	0.250	20	12	88.9	89.9	6.4	508.0	304.8
►	4	102	4.500	4.540	0.250	20	12	114.3	115.3	6.4	508.0	304.8
►	5	127	5.500	5.540	0.250	20	12	139.7	140.7	6.4	508.0	304.8
►	6	152	6.500	6.540	0.250	20	12	165.1	166.1	6.4	508.0	304.8
+	8	203	8.893	8.933	0.250	20	12	225.9	226.9	6.4	508.0	304.8

ID/IPS XHW O-RING EXPANSION JOINT

► ID Product
+ IPS Product

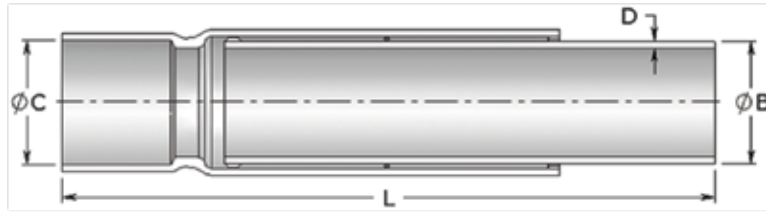

Size	ØB		ØC	D	L min	L max	ØB			L min	L max
	in	mm					inches	in	mm		
► 2	51	2.500	2.540	0.250	23	35	63.5	64.5	6.4	584.2	889.0
► 3	76	3.500	3.540	0.250	23	35	88.9	89.9	6.4	584.2	889.0
► 4	102	4.500	4.540	0.250	23	35	114.3	115.3	6.4	584.2	889.0
► 5	127	5.500	5.540	0.250	23	35	139.7	140.7	6.4	584.2	889.0
► 6	152	6.500	6.540	0.250	23	35	165.1	166.1	6.4	584.2	889.0
+ 8	203	8.893	8.933	0.250	23	35	225.9	226.9	6.4	584.2	889.0

ID/IPS XHW O-RING EXPANSION / DEFLECTION JOINT

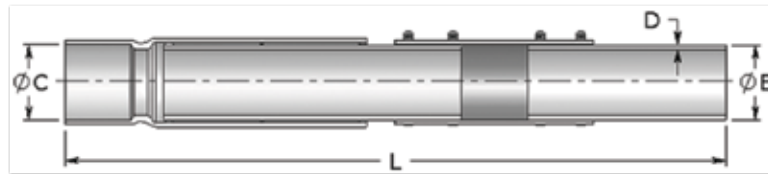

Size	ØB		ØC	D	L min	L max	ØB			L min	L max
	in	mm					inches	in	mm		
► 2	51	2.500	2.540	0.250	39	51	63.5	64.5	6.4	990.6	1295.4
► 3	76	3.500	3.540	0.250	39	51	88.9	89.9	6.4	990.6	1295.4
► 4	102	4.500	4.540	0.250	39	51	114.3	115.3	6.4	990.6	1295.4
► 5	127	5.500	5.540	0.250	39	51	139.7	140.7	6.4	990.6	1295.4
► 6	152	6.500	6.540	0.250	39	51	165.1	166.1	6.4	990.6	1295.4
+ 8	203	8.893	8.933	0.250	39	51	225.9	226.9	6.4	990.6	1295.4

ID/IPS XHW WOBBLE

Part Number Ordering Matrix Begins On Page 90

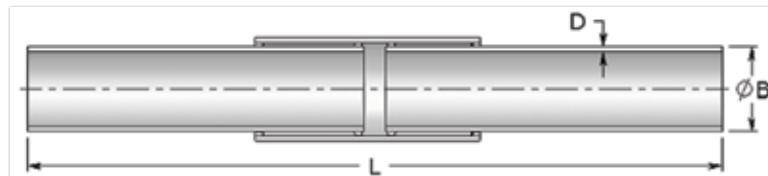

Size	ØB		D	L min	L max	ØB			L min	L max
	in	mm				inches	in	mm		
► 2	51	2.500	0.250	36	46	63.5	6.4	914.4	1168.4	
► 3	76	3.500	0.250	36	46	88.9	6.4	914.4	1168.4	
► 4	102	4.500	0.250	36	46	114.3	6.4	914.4	1168.4	
► 5	127	5.500	0.250	36	46	139.7	6.4	914.4	1168.4	
► 6	152	6.500	0.250	36	46	165.1	6.4	914.4	1168.4	
+ 8	203	8.893	0.250	36	46	225.9	6.4	914.4	1168.4	

FIBERGLASS CONDUIT

ID/IPS XHW SKEW WOBBLE

► ID Product
+ IPS Product

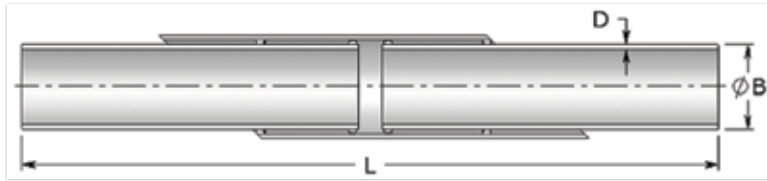

	Size	ØB	D	L min	L max	ØB	D	L min	L max
	in mm		inches				millimeters		
►	2 51	2.500	0.250	48	56	63.5	6.4	1219.2	1422.4
►	3 76	3.500	0.250	48	56	88.9	6.4	1219.2	1422.4
►	4 102	4.500	0.250	48	56	114.3	6.4	1219.2	1422.4
►	5 127	5.500	0.250	48	56	139.7	6.4	1219.2	1422.4
►	6 152	6.500	0.250	48	56	165.1	6.4	1219.2	1422.4
+	8 203	8.893	0.250	48	56	225.9	6.4	1219.2	1422.4

ID/IPS XHW NPT FEMALE THREADED ADAPTER

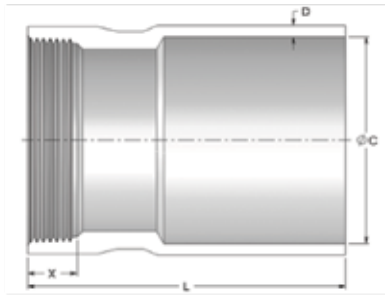

	Size	ØC	D	L	X	ØC	D	L	X
	in mm		inches				millimeters		
►	2 51	2.540	0.250	7	0.697	64.5	6.4	177.8	17.7
►	3 76	3.540	0.250	7	1.016	89.9	6.4	177.8	25.8
►	4 102	4.540	0.250	7	1.094	115.3	6.4	177.8	27.8
►	5 127	5.540	0.250	7	1.187	140.7	6.4	177.8	30.1
►	6 152	6.540	0.250	7	1.208	166.1	6.4	177.8	30.7
+	8 203	8.933	0.250	7	1.313	226.9	6.4	177.8	33.4

ID/IPS XHW NPT MALE THREADED ADAPTER

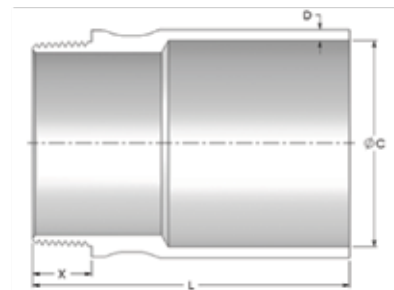

	Size	ØC	D	L	X	ØC	D	L	X
	in mm		inches				millimeters		
►	2 51	2.540	0.250	7	0.757	64.5	6.4	177.8	19.2
►	3 76	3.540	0.250	7	1.200	89.9	6.4	177.8	30.5
►	4 102	4.540	0.250	7	1.300	115.3	6.4	177.8	33.0
►	5 127	5.540	0.250	7	1.406	140.7	6.4	177.8	35.7
►	6 152	6.540	0.250	7	1.513	166.1	6.4	177.8	38.4
+	8 203	8.933	0.250	7	1.713	226.9	6.4	177.8	43.5

**Part Number
Ordering
Matrix Begins
On Page 90**

ID XHW REDUCER

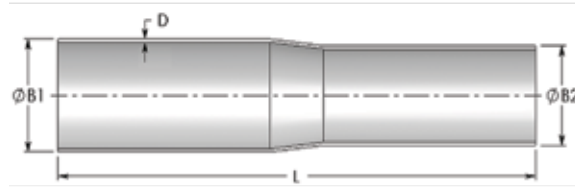

► ID Product
+ IPS Product

	Size	ØB1	ØB2	D	L	ØB1	ØB2	D	L	
	in		inches			millimeters	millimeters			
►	3	76	3.500	2.500	0.250	18	88.9	63.5	6.4	457.2
►	4	102	4.500	3.500	0.250	18	114.3	88.9	6.4	457.2
►	5	127	5.500	4.500	0.250	18	139.7	114.3	6.4	457.2
►	6	152	6.500	5.500	0.250	18	165.1	139.7	6.4	457.2

ID XHW MULTIFIT ADAPTER

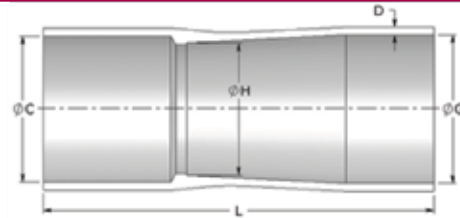

	Size	ØC	D	ØG	ØH	L	ØC	D	ØG	ØH	L	
	in	mm		inches			millimeters		millimeters			
►	2	51	2.540	0.250	2.239	2.424	12.25	64.5	6.4	56.9	61.6	311.2
►	3	76	3.540	0.250	3.239	3.549	12.25	89.9	6.4	82.3	90.1	311.2
►	4	102	4.540	0.250	4.109	4.620	12.25	115.3	6.4	104.4	117.3	311.2
►	5	127	5.540	0.250	5.289	5.650	12.25	140.7	6.4	134.3	143.5	311.2
►	6	152	6.540	0.250	6.259	6.686	12.25	166.1	6.4	159.0	169.8	311.2

ID/IPS XHW SPLIT STOP RING

	Size	ØC	D	L	ØC	D	L	
	in	mm	inches		millimeters			
►	2	51	2.540	0.250	2	64.5	6.4	50.8
►	3	76	3.540	0.250	2	89.9	6.4	50.8
►	4	102	4.540	0.250	2	115.3	6.4	50.8
►	5	127	5.540	0.250	2	140.7	6.4	50.8
►	6	152	6.540	0.250	2	166.1	6.4	50.8
+	8	203	8.933	0.250	2	226.9	6.4	50.8

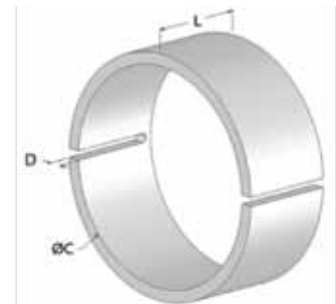

ID/IPS ID XHW 11.25° FITTING

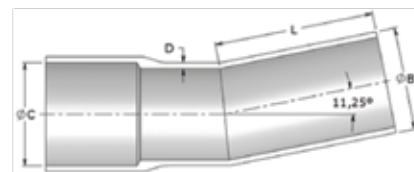

	Size	ØB	ØC	D	L	ØB	ØC	D	L	
	in	mm	inches			millimeters	millimeters			
►	2	51	2.500	2.540	0.250	7	63.5	64.5	6.4	177.8
►	3	76	3.500	3.540	0.250	7	88.9	89.9	6.4	177.8
►	4	102	4.500	4.540	0.250	7	114.3	115.3	6.4	177.8
►	5	127	5.500	5.540	0.250	7	139.7	140.7	6.4	177.8
►	6	152	6.500	6.540	0.250	7	165.1	166.1	6.4	177.8
+	8	203	8.893	8.933	0.250	7	225.9	226.9	6.4	177.8

**Part Number
Ordering
Matrix Begins
On Page 90**

FIBERGLASS CONDUIT

ID XHW 11.25° ELBOW

► ID Product

+ IPS Product

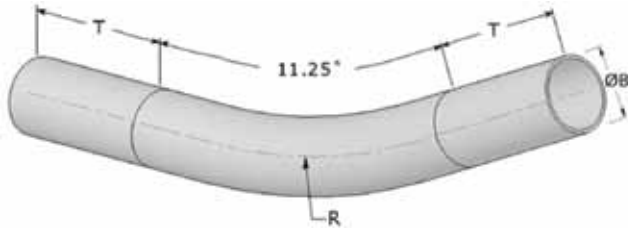

48" RADIUS

Size		ØB	R	T	ØB R T			
in	mm				millimeters			
►	2	51	2.500	48	6	63.5	1219.2	152.4
►	3	76	3.500	48	6	88.9	1219.2	152.4
►	4	102	4.500	48	6	114.3	1219.2	152.4
►	5	127	5.500	48	6	139.7	1219.2	152.4
►	6	152	6.500	48	6	165.1	1219.2	152.4

36" RADIUS

Size		ØB	R	T	ØB R T			
in	mm				millimeters			
►	2	51	2.500	36	6	63.5	914.4	152.4
►	3	76	3.500	36	6	88.9	914.4	152.4
►	4	102	4.500	36	6	114.3	914.4	152.4
►	5	127	5.500	36	6	139.7	914.4	152.4

60" RADIUS

Size		ØB	R	T	ØB R T			
in	mm				millimeters			
►	2	51	2.500	60	6	63.5	1524.0	152.4
►	3	76	3.500	60	6	88.9	1524.0	152.4
►	4	102	4.500	60	6	114.3	1524.0	152.4
►	5	127	5.500	60	6	139.7	1524.0	152.4
►	6	152	6.500	60	6	165.1	1524.0	152.4

FIBERGLASS CONDUIT

ID XHW 22.5° ELBOW

**Part Number
Ordering
Matrix Begins
On Page 90**

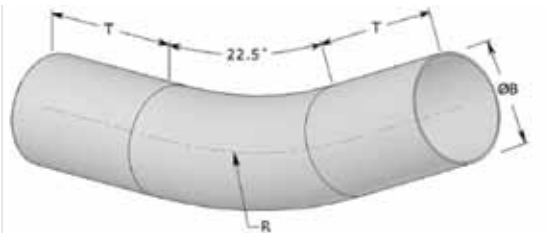

24" RADIUS

Size		ØB	R	T	ØB R T			
in	mm				millimeters			
►	2	51	2.500	24	6	63.5	609.6	152.4
►	3	76	3.500	24	6	88.9	609.6	152.4

48" RADIUS

Size		ØB	R	T	ØB R T			
in	mm				millimeters			
►	2	51	2.500	48	6	63.5	1219.2	152.4
►	3	76	3.500	48	6	88.9	1219.2	152.4
►	4	102	4.500	48	6	114.3	1219.2	152.4
►	5	127	5.500	48	6	139.7	1219.2	152.4
►	6	152	6.500	48	6	165.1	1219.2	152.4

36" RADIUS

Size		ØB	R	T	ØB R T			
in	mm				millimeters			
►	2	51	2.500	36	6	63.5	914.4	152.4
►	3	76	3.500	36	6	88.9	914.4	152.4
►	4	102	4.500	36	6	114.3	914.4	152.4
►	5	127	5.500	36	6	139.7	914.4	152.4

60" RADIUS

Size		ØB	R	T	ØB R T			
in	mm				millimeters			
►	2	51	2.500	60	6	63.5	1524.0	152.4
►	3	76	3.500	60	6	88.9	1524.0	152.4
►	4	102	4.500	60	6	114.3	1524.0	152.4
►	5	127	5.500	60	6	139.7	1524.0	152.4
►	6	152	6.500	60	6	165.1	1524.0	152.4

ID XHW 30° ELBOW

► ID Product
+ IPS Product

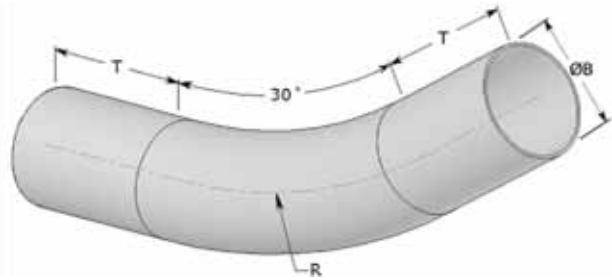

48" RADIUS

Size	Size		ØB	R	T	ØB R T		
	in	mm				millimeters		
► 2	51	2.500	48	6	63.5	1219.2	152.4	
► 3	76	3.500	48	6	88.9	1219.2	152.4	
► 4	102	4.500	48	6	114.3	1219.2	152.4	
► 5	127	5.500	48	6	139.7	1219.2	152.4	
► 6	152	6.500	48	6	165.1	1219.2	152.4	

36" RADIUS

Size	Size		ØB	R	T	ØB R T		
	in	mm				millimeters		
► 2	51	2.500	36	6	63.5	914.4	152.4	
► 3	76	3.500	36	6	88.9	914.4	152.4	
► 4	102	4.500	36	6	114.3	914.4	152.4	
► 5	127	5.500	36	6	139.7	914.4	152.4	

60" RADIUS

Size	Size		ØB	R	T	ØB R T		
	in	mm				millimeters		
► 2	51	2.500	60	6	63.5	1524.0	152.4	
► 3	76	3.500	60	6	88.9	1524.0	152.4	
► 4	102	4.500	60	6	114.3	1524.0	152.4	
► 5	127	5.500	60	6	139.7	1524.0	152.4	
► 6	152	6.500	60	6	165.1	1524.0	152.4	

ID XHW 45° ELBOW

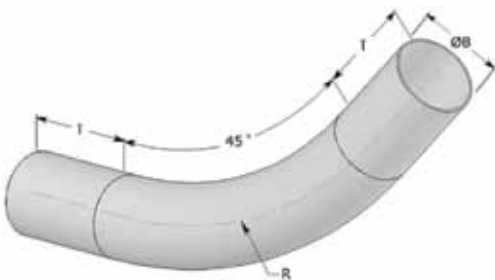

48" RADIUS

Size	Size		ØB	R	T	ØB R T		
	in	mm				millimeters		
► 2	51	2.500	48	6	63.5	1219.2	152.4	
► 3	76	3.500	48	6	88.9	1219.2	152.4	
► 4	102	4.500	48	6	114.3	1219.2	152.4	
► 5	127	5.500	48	6	139.7	1219.2	152.4	
► 6	152	6.500	48	6	165.1	1219.2	152.4	

36" RADIUS

Size	Size		ØB	R	T	ØB R T		
	in	mm				millimeters		
► 2	51	2.500	36	6	63.5	914.4	152.4	
► 3	76	3.500	36	6	88.9	914.4	152.4	
► 4	102	4.500	36	6	114.3	914.4	152.4	
► 5	127	5.500	36	6	139.7	914.4	152.4	

60" RADIUS

Size	Size		ØB	R	T	ØB R T		
	in	mm				millimeters		
► 2	51	2.500	60	6	63.5	1524.0	152.4	
► 3	76	3.500	60	6	88.9	1524.0	152.4	
► 4	102	4.500	60	6	114.3	1524.0	152.4	
► 5	127	5.500	60	6	139.7	1524.0	152.4	
► 6	152	6.500	60	6	165.1	1524.0	152.4	

**Part Number
Ordering
Matrix Begins
On Page 90**

FIBERGLASS CONDUIT

ID XHW 60° ELBOW

► ID Product

+ IPS Product

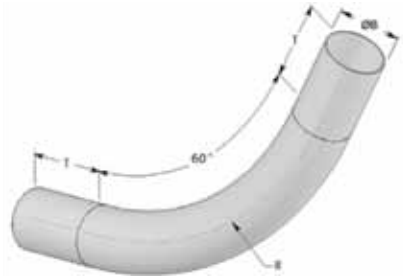

48" RADIUS

Size		ØB	R	T	ØB R T			
in	mm				millimeters			
►	2	51	2.500	48	6	63.5	1219.2	152.4
►	3	76	3.500	48	6	88.9	1219.2	152.4
►	4	102	4.500	48	6	114.3	1219.2	152.4
►	5	127	5.500	48	6	139.7	1219.2	152.4
►	6	152	6.500	48	6	165.1	1219.2	152.4

36" RADIUS

Size		ØB	R	T	ØB R T			
in	mm				millimeters			
►	2	51	2.500	36	6	63.5	914.4	152.4
►	3	76	3.500	36	6	88.9	914.4	152.4
►	4	102	4.500	36	6	114.3	914.4	152.4
►	5	127	5.500	36	6	139.7	914.4	152.4

60" RADIUS

Size		ØB	R	T	ØB R T			
in	mm				millimeters			
►	2	51	2.500	60	6	63.5	1524.0	152.4
►	3	76	3.500	60	6	88.9	1524.0	152.4
►	4	102	4.500	60	6	114.3	1524.0	152.4
►	5	127	5.500	60	6	139.7	1524.0	152.4
►	6	152	6.500	60	6	165.1	1524.0	152.4

FIBERGLASS CONDUIT

ID XHW 90° ELBOW

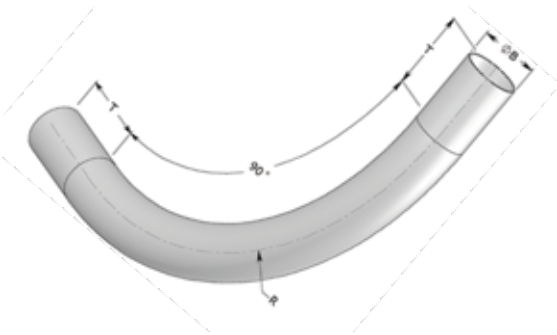

48" RADIUS

Size		ØB	R	T	ØB R T			
in	mm				millimeters			
►	2	51	2.500	48	6	63.5	1219.2	152.4
►	3	76	3.500	48	6	88.9	1219.2	152.4
►	4	102	4.500	48	6	114.3	1219.2	152.4
►	5	127	5.500	48	6	139.7	1219.2	152.4
►	6	152	6.500	48	6	165.1	1219.2	152.4

36" RADIUS

Size		ØB	R	T	ØB R T			
in	mm				millimeters			
►	2	51	2.500	36	6	63.5	914.4	152.4
►	3	76	3.500	36	6	88.9	914.4	152.4
►	4	102	4.500	36	6	114.3	914.4	152.4

60" RADIUS

Size		ØB	R	T	ØB R T			
in	mm				millimeters			
►	2	51	2.500	60	6	63.5	1524.0	152.4
►	3	76	3.500	60	6	88.9	1524.0	152.4
►	4	102	4.500	60	6	114.3	1524.0	152.4
►	5	127	5.500	60	6	139.7	1524.0	152.4
►	6	152	6.500	60	6	165.1	1524.0	152.4

**Part Number
Ordering
Matrix Begins
On Page 90**